

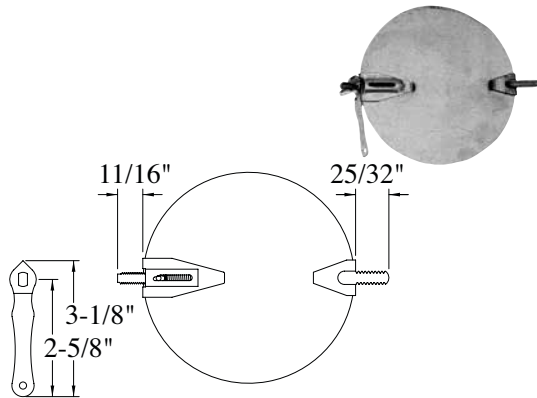

JDS, JD, JDE, QJDE Jiffy Dampers



The "JDS" Series Jiffy Damper offers the contractor a quality round damper at a cost lower than most shop-made dampers. The Duro Dyne JDS series utilizes quality Rapit Spring and Rapit Solid End Bearing sets.

Blade gauge is as follows: 4" thru 8" are 26ga galvanized steel and 9" & 14" are 24ga galvanized steel.

JDS JIFFY DAMPERS			
ITEM#	CODE	FOR DUCT SIZE DIA.	QTY
8092	JDS4	4"	10 Per Ctn
8093	JDS5	5"	10 Per Ctn
8094	JDS6	6"	10 Per Ctn
8095	JDS7	7"	10 Per Ctn
8096	JDS8	8"	10 Per Ctn
8097	JDS9	9"	10 Per Ctn
8137	JDS10	10"	10 Per Ctn
7188	JDS12	12"	10 Per Ctn
7189	JDS14	14"	10 Per Ctn

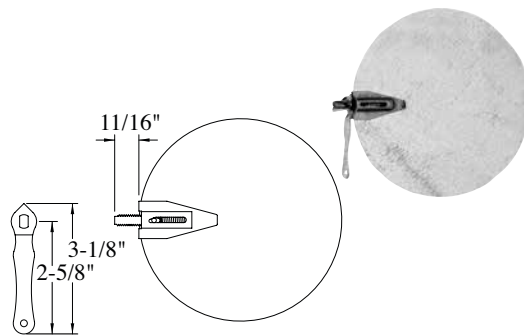

The "JD" Series Jiffy Damper offers added economy in those applications where a supporting solid tail bearing is not required on the damper. The Duro Dyne JD Damper utilizes one Rapit Spring End Bearing.

Blade gauge is as follows: 4" thru 8" are 26ga galvanized steel and 9" & 10" are 24ga galvanized steel.

JD JIFFY DAMPERS			
ITEM#	CODE	FOR DUCT SIZE DIA.	QTY
8098	JD4	4"	10 Per Ctn
8099	JD5	5"	10 Per Ctn
8100	JD6	6"	10 Per Ctn
8101	JD7	7"	10 Per Ctn
8146	JD8	8"	10 Per Ctn
8140	JD10	10"	10 Per Ctn

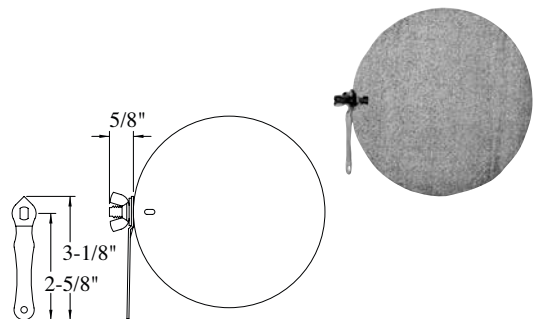

The "QJDE" Series Jiffy Damper offers an inexpensive alternative for low pressure applications. The Duro Dyne Economy Damper utilizes one threaded stud as a support bearing.

Blade gauge is as follows: 5" thru 8" are 26ga galvanized steel.

QJDE JIFFY DAMPERS			
ITEM#	CODE	FOR DUCT SIZE DIA.	QTY
6238	QJDE5H*	5"	100 Per Ctn
6239	QJDE6H*	6"	100 Per Ctn
6240	QJDE7H*	7"	100 Per Ctn
6241	QJDE8H*	8"	100 Per Ctn
6245	QJDE6HW**	6"	100 Per Ctn
6246	QJDE7HW**	7"	100 Per Ctn
*Unattached			
**Bag attached			

